



RUSSIAN FEDERATION
MINISTRY OF TRANSPORT OF RUSSIAN FEDERATION
FEDERAL AIR TRANSPORT AGENCY

AIRWORTHINESS DIRECTIVE

22 May, 2019

Ref. No. 2019-322-03

Applicability – RRJ-95 aircraft

State of Design – Russian Federation

Corrective actions described herein are mandatory. No operator may operate an aircraft to which this AD applies, except in accordance with the requirements hereof.

Pursuant to revealing of the slat section track link crack on RRJ-95 aircraft,

WE PROPOSE:

1. Starting from 15.06.2019, during the weekly WY-Check/8 DY on A/C RRJ-95 MSN 95030, 95037 and from 95116 to 95220, to perform the inspections of links of tracks (See. Fig.1 (it. 1, 2) and Fig.2 (it. 3) and bearings of links of track of sections 2, 3 and 4 of slat of LH and RH outer wings in accordance with the provisions of p. 4. Б. (2) and (6) of AMM Tasks No. 57-43-00-220-802, 57-44-00-220-802 and 57-45-00-220-802, until the implementation of SB No. RRJ-57-00451-BD “Wing – Replacement of link of track of slat section” (Planned release date of the SB – 23.05.2019г.)

NOTE: Until the above AMM Tasks are released according to the established procedure, please be guided by Information Letter No. 57-0576-19 rev.00 dated 13.05.2019.

2. In case of finding a crack of link of track and/or deterioration and press-out of the bearing of link of track of sections 2, 3 and 4 of slat of LH and RH outer wings following the results of implementation of p.1 hereof, it is necessary to replace the damaged track link assembly (track link and bearing), according to the identification information in Table 1 and under the instructions given in AMM Tasks No. 57-43-00-900-804, 57-44-00-900-804 and 57-45-00-900-804

Once the track link assembly is replaced, continue the inspections of the track links (See Fig.1 (items 1, 2) and Fig.2 (item 3) and the bearings of links of track of sections 2, 3 and 4 of slat of LH and RH outer wings during the weekly WY-Check/8 DY in accordance with the provisions of p.1 hereof and subject to the following conditions:

1) In case of partial replacement of the track link assemblies, perform inspections in full, including inspection of the replaced items;

2) In case of full replacement of the track link assemblies, SB No. RRJ-57-00451-BD “Wing – Replacement of link of track of slat section” shall be considered implemented; the inspections shall be performed in accordance with the MPD requirements.

Please send the results of implementation of the provisions of paragraphs 1-2 to the Operational Situation Center at: customercare@scac.ru.

Table 1.

Track No.	Installed on AC	Install in replacement of	Applicability
3	T7.92.3621.515.000.70/A	T7.92.3621.515.100.70/A	95030, 95037, 95116-95220
3, 5	T7.92.3621.520.000.70/A	T7.92.3621.520.100.70/A	95030, 95037, 95116-95220
4	T7.92.3621.615.000.70/A	T7.92.3621.615.105.70/A	95030, 95037, 95116-95144
4	T7.92.3621.615.000.70/B	T7.92.3621.615.100.70/A	95145-95220
5	T7.92.3621.525.000.70/A	T7.92.3621.525.100.70/A	95030, 95037, 95116-95220
6	T7.92.3631.615.000.70/A	T7.92.3631.615.100.70/A	95030, 95037, 95116-95220
7	T7.92.3631.515.000.70/A	T7.92.3631.515.100.70/A	95030, 95037, 95116-95220
7	T7.92.3631.520.000.70/A	T7.92.3631.520.100.70/A	95030, 95037, 95116-95220
8	T7.92.3641.615.000.70/A	T7.92.3641.615.100.70/A	95030, 95037, 95116-95220
9	T7.92.3641.515.000.70/A	T7.92.3641.515.100.70/A	95030, 95037, 95116-95220
9	T7.92.3641.520.000.70/A	T7.92.3641.520.100.70/A	95030, 95037, 95116-95220

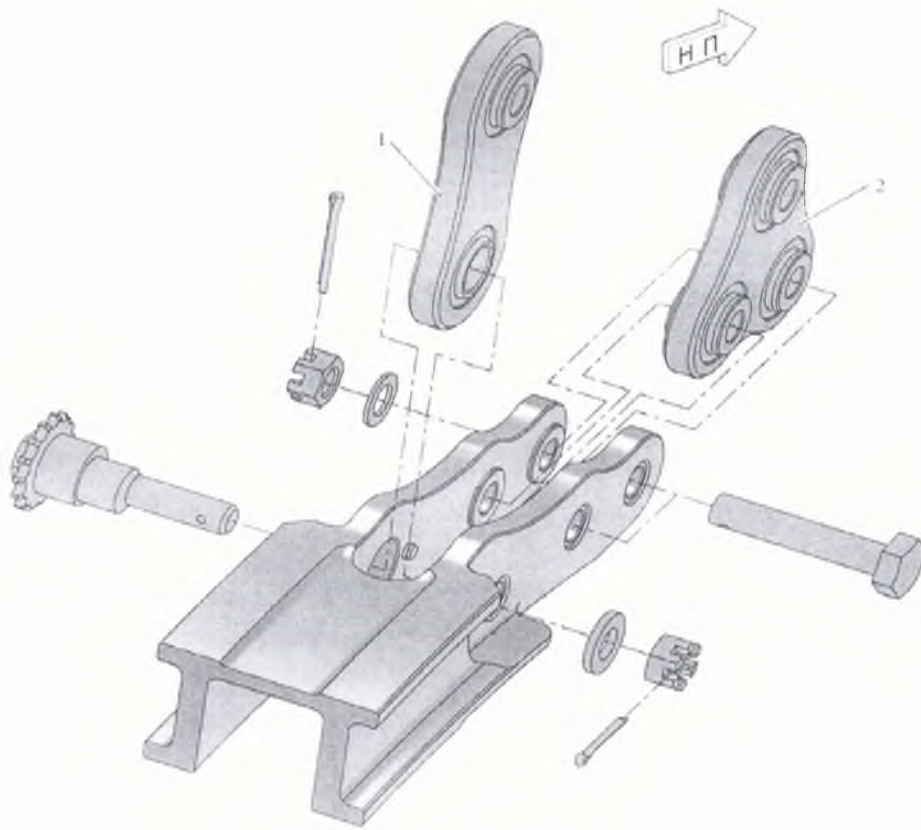

Fig.1

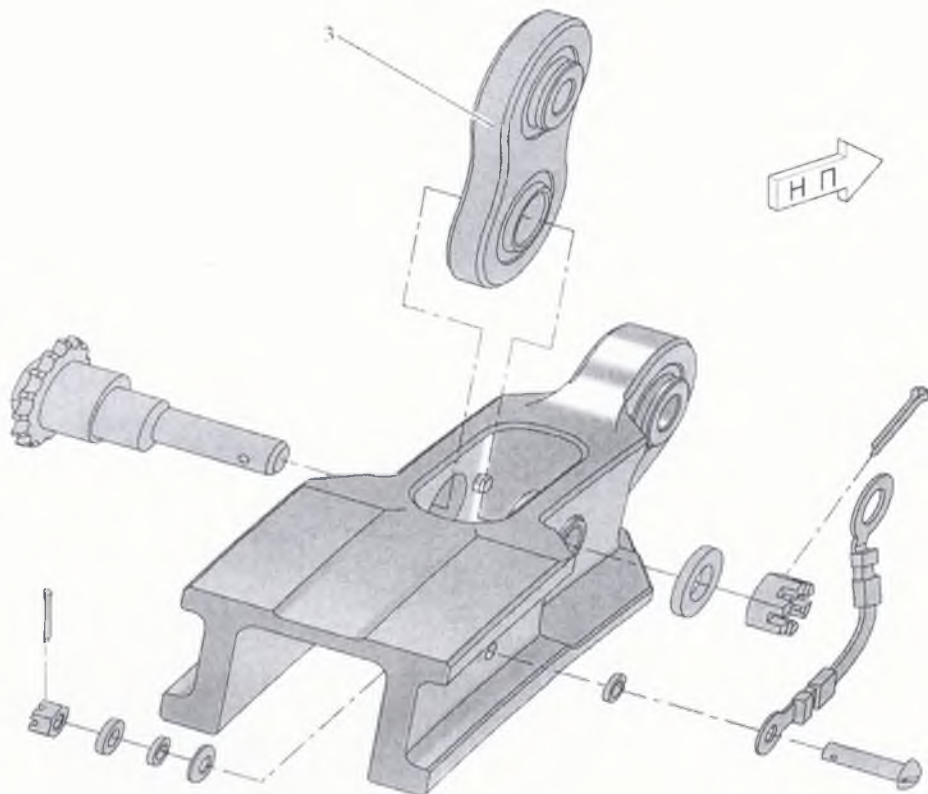
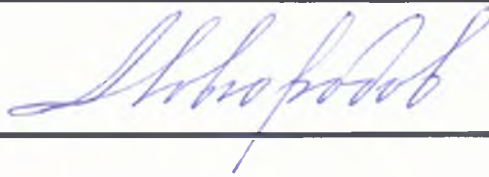

Fig.2

Appendix: Technical Decision No. RRJ0000-OR-470-3016 dated 14.05.2019,
Information Letter No. 57-0576-19 rev.00 dated 13.05.2019 – on 29 pages, in 1 copy.

**Deputy Head of the Federal Air
Transport Agency**



A. Novgorodov
